



minimal warm up time

variable output

minimal noise

made in Germany

The haze machine **Unique²** (follow-up model of the Unique) offers various features, which open up new fields of operation to the user.

Not only the design has been changed, the **Unique²** is also equipped with new features like an internal Timer and a brand new Haze-Density Control System (HDCS). With this HDCS an individual profile for a show can be programmed.

Due to the new, more efficient fan, the haze can be distributed in the room quickly. A replaceable filter protects the fan against dirt.

With its variable output, the machine can be used in many fields. Any desired effect can be achieved: from the finest mist to a thick haze, similar to fog. Therefore the machine is able to fill small and big rooms or halls with a constant haze, creating the right atmosphere and excellently supporting lighting effects.

Features

- Minimal warming up time

The very short warming up time of approx. 60 seconds means the **Unique²** is ready for operation almost immediately.

A continuous output is guaranteed by the fact that the machine does not have to warm up during operation.

- Variable output

The pump and the fan of the machine can be adjusted separately in 99 steps. Thus the user is able to adjust the density and output exactly.

A non-linear pump regulation make sure that the pump can be adjusted much better at the lower steps.

- Minimal sound

Due to the fact that the pump and the fan can be dampened, the sound of the **Unique²** can be ab-

sorbed tremendously. So the machine can be used in fields of operation where any sound is undesirable and disturbing.

- Buttons and LED's

The control of the pump and fan, the adjusting of the DMX start address and also the adjusting of the Timer and the HDCS is achieved with buttons. The adjusted data can be read at the LED-Display.

- DMX 512 as standard

The **Unique²** can be controlled via DMX 512. Pump and fan can be adjusted separately. The connection is done with 5-pin-XLR plugs using two following control channels at the desk.

The machine can also be controlled with analogue (0-10V) via a lighting desk and via cable remote (option). This connection is done with 3-pin-XLR plugs. A stand-alone running is also possible. The adjustments are done directly at the machine.

- Internal Timer

With the internal Timer the haze time can be exactly adjusted in seconds, the wait time in minutes and the output of pump and fan in %.

- Haze-Density Control System (HDCS)

With the HDCS an individual Profile for a Show can be programmed. Two Levels with the required pump and fan values along with a haze time can be adjusted. Additionally a pre-runtime can be programmed.

- Minimal fluid consumption

A special fluid guarantees minimal fluid consumption, low running costs and an optimal haze effect. It is supplied in 2l-canisters.

One of these canisters guarantees up to 50 hours of continuous output.

Technical Data

Procedure	Haze machine without compressor
Power requirement	1500 Watt
Voltage	230 V/50 Hz or 120V/60Hz
Warm up time	approx. 60 sec.
Fluid tank capacity	2 Liter
Internal fan	> 6000 l/min.
Haze density	adjustable in 99 steps
Control	DMX 512 0 – 10 V analog Stand-alone-Mode XLR-remote (option)
Dimensions (L x W x H)	47 x 25 x 25 cm
Weight without bottle	approx. 8.7 kg

Dimensions

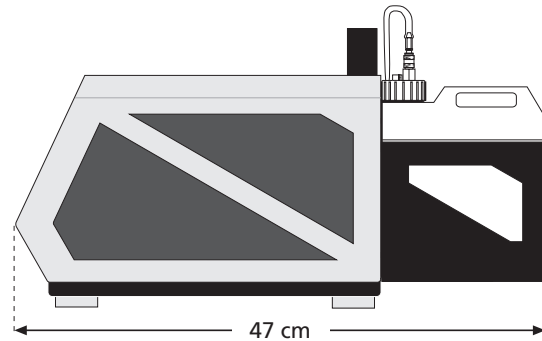
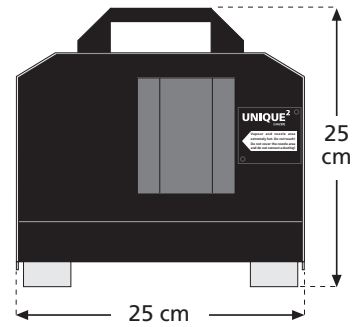

Advantages

- Minimal warm up time (approx. 60 sec.)
- Pump and fan adjustable in 99 steps, therefore variable output (from the finest mist to a thick haze, similar to fog)
- Internal fan for quick and homogen distribution
- DMX as standard, analog (0-10V) and stand-alone running
- Control of the pump, fan and the adjusting of the DMX start address is achieved with buttons
- Internal Timer
- Haze-density Control System (HDCS)
- Can be controlled via cable remote (option)
- Very silent
- Minimal fluid consumption (2l canister guarantees up to 50 hours continuous output)
- Made in Germany

Accessories

- Cable remote
- Diverter to divert the direction of the output
- Hanging set
(Hanging yoke complete with collection tray)
- Case

Service

Based on the strong partnership with the German manufacturer OTTEC Technology GmbH, Look Solutions is able to provide a quick and easy service which guarantees the high quality of all products with the motto „innovation by communication“.

Distributed By:

Theatre Effects
Cincinnati, OH 45246
Phone: 513-791-7646
Fax: 513-772-3579
service@theatrefx.com
www.theatrefx.com